

THIS DRAWING IS UNPUBLISHED. RELEASED FOR PUBLICATION  
 © COPYRIGHT - By - ALL RIGHTS RESERVED.

LOC	DIST	REVISIONS					
HM	00	P	LTR	DESCRIPTION	DATE	DWN	APVD
		F		REV PER ECO-12-012918	09JUL2012	JM	JG

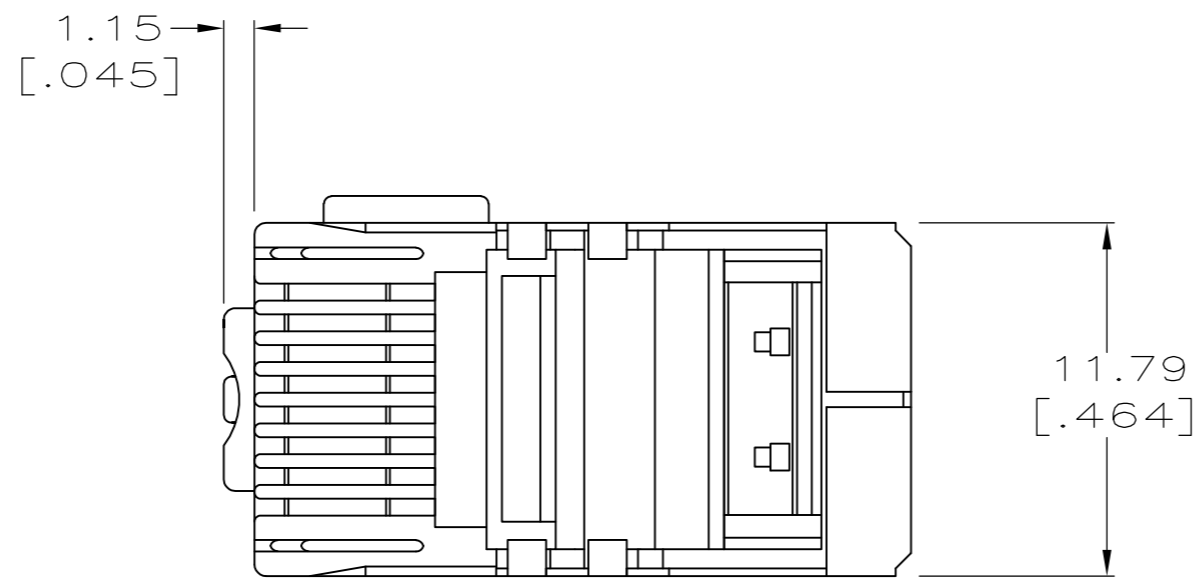

- 1. DIMENSIONS ARE MAXIMUM UNLESS OTHERWISE SPECIFIED.
- 2. MATERIAL: HOUSING-POLYCARBONATE, CLEAR  
 TERMINAL- PHOSPHOR BRONZE, PLATED WITH 1.27μm [.000050] MINIMUM THICK GOLD IN LOCALIZED GOLD PLATE AREA, OVER 2.54μm [.000100] MINIMUM THICK NICKEL UNDERPLATE.  
 SHIELD - COPPER ALLOY WITH 1.27μm [.000050] MINIMUM SEMI-BRIGHT (SATIN) NICKEL.

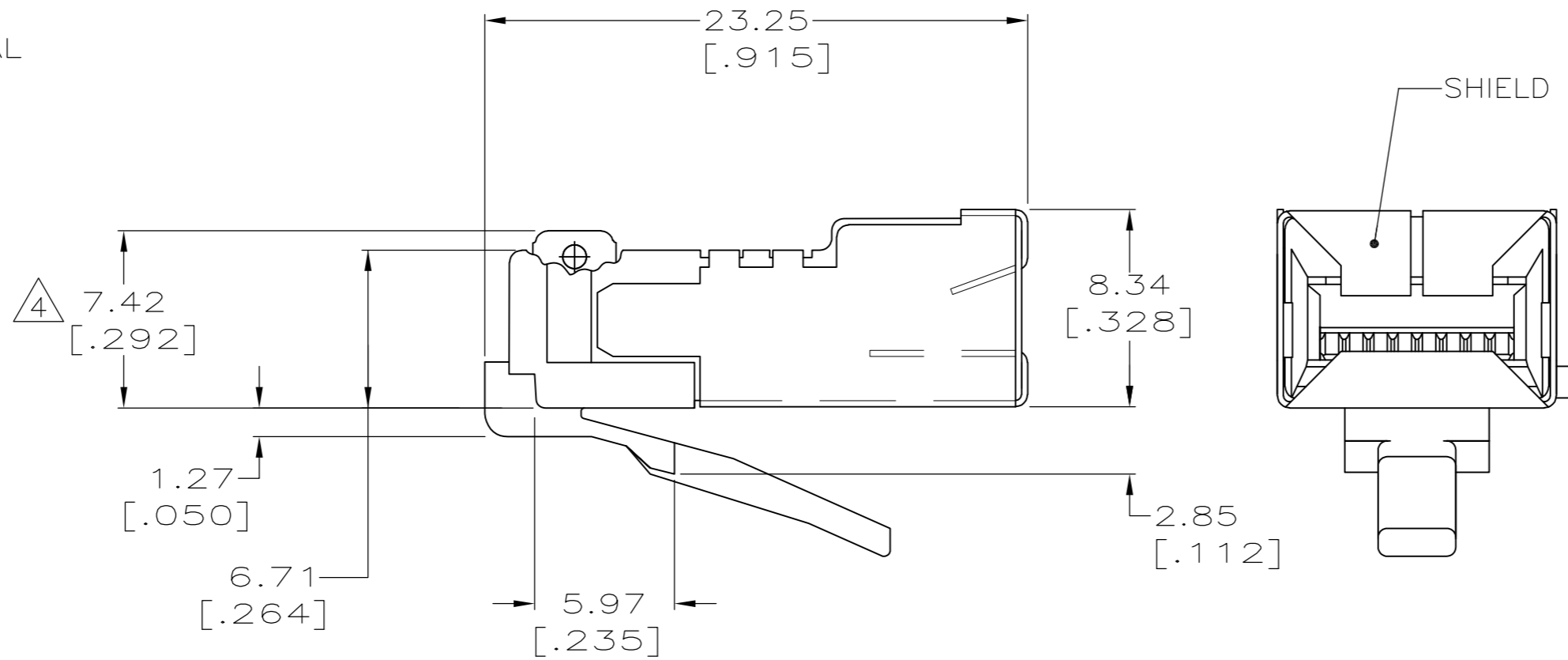
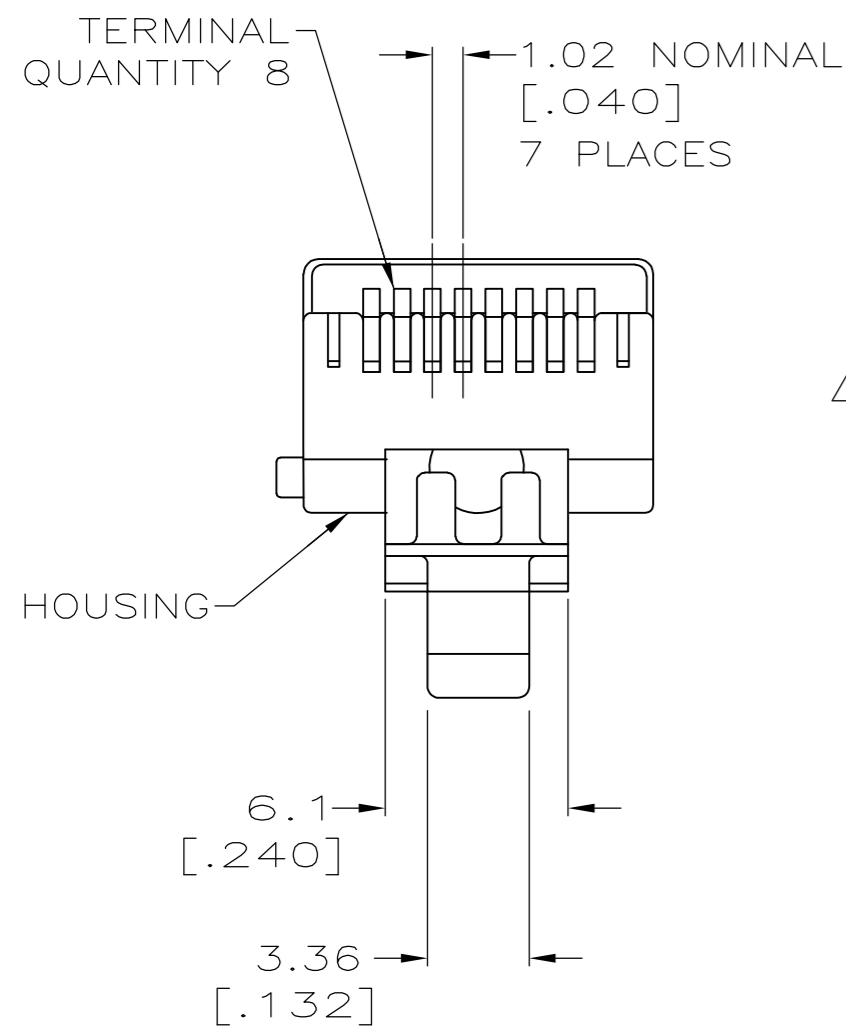

- 3. PLUG WILL ACCEPT 24 TO 28 AWG STRANDED WIRE, 0.74-0.99 [.029-.039] DIAMETER, WITH A 2.80 X 9.02 [.110 X .355] MAXIMUM JACKET.
- 4. TERMINATED DIMENSION 6.15 [.242] MAXIMUM.
- 5. 500 ASSEMBLIES PER PACKAGE.

5	5-569543-2
PACKAGED	PART NUMBER

THIS DRAWING IS A CONTROLLED DOCUMENT.		DWN	G. GARRETT	10-10-95	<b>TE</b> TE Connectivity																		
DIMENSIONS: mm [INCHES]		CHK	C. WHITT	10-30-95																			
TOLERANCES UNLESS OTHERWISE SPECIFIED:		APVD	E. LAURER	11-6-95																			
<table border="0"> <tr><td>0 PLC</td><td>± -</td><td rowspan="4" style="text-align: center;">1</td></tr> <tr><td>1 PLC</td><td>± -</td></tr> <tr><td>2 PLC</td><td>± -</td></tr> <tr><td>3 PLC</td><td>± -</td></tr> <tr><td>4 PLC</td><td>± -</td><td></td></tr> <tr><td>ANGLES</td><td>± -</td><td></td></tr> <tr><td>FINISH</td><td>± -</td><td style="text-align: center;">2</td></tr> </table>		0 PLC	± -	1		1 PLC	± -	2 PLC	± -	3 PLC	± -	4 PLC	± -		ANGLES	± -		FINISH	± -	2	PRODUCT SPEC	108-1163	NAME
0 PLC	± -	1																					
1 PLC	± -																						
2 PLC	± -																						
3 PLC	± -																						
4 PLC	± -																						
ANGLES	± -																						
FINISH	± -	2																					
MATERIAL	-	APPLICATION SPEC	114-6016	SIZE	A2																		
		WEIGHT	-	CAGE CODE	00779																		
		CUSTOMER DRAWING		DRAWING NO	C=569543																		
				RESTRICTED TO	-																		
				SCALE	4:1																		
				SHEET	1 of 1																		
				REV	F																		