

REVISIONS

P	LTR	DESCRIPTION	DATE	DWN	APVD
	B1	REDRAWN AND REV. BY ECO 16-005110	11JULY2016	HC	WLS
	B2	REVISED BY ECO 16-010925	25JULY2016	HC	WLS

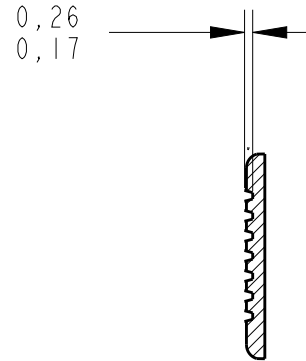

SCALE 2:1

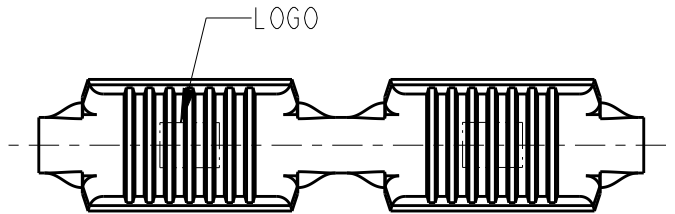

SECTION A - A

SMALL DISTORTION PERMITTED

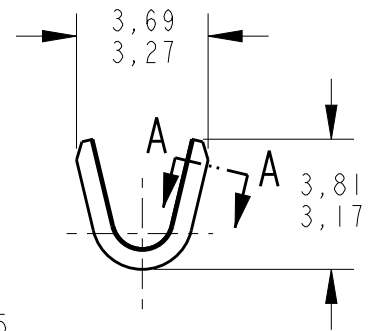
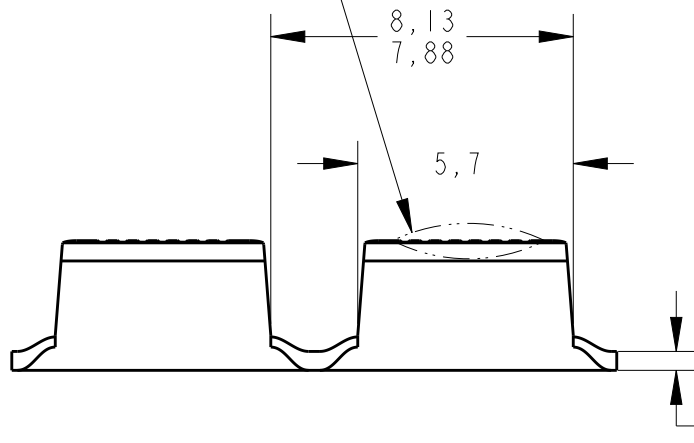

0,50±0,05

⚠ -NOT FOR USE WITH ALUMINUM MAGNET WIRE, USE WITH COPPER MAGNET WIRE ONLY.

WIRE RANGE  
600-3000 CMA

TIN PLATED	BRASS	280004-2
—	BRASS	280004-1 ⚠
FINISH	MATERIAL	PART NUMBER

RELEASED FOR PUBLICATION

ALL RIGHTS RESERVED.

THIS DRAWING IS UNPUBLISHED.

© COPYRIGHT copyright\_date

DIMENSIONS:

mm

TOLERANCES UNLESS OTHERWISE SPECIFIED:

0 PLC	±-
1 PLC	±0,2
2 PLC	±0,4
3 PLC	±-
4 PLC	±-
ANGLES	±-

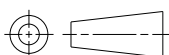

DWN 20JAN2015

H.C.CANTERI

CHK 22JAN2015

W.L.STEFANI

APVD -

PRODUCT SPEC

-

APPLICATION SPEC

-

WEIGHT

-

MATERIAL

-

FINISH

-



TE Connectivity

NAME AMPLIVAR SPLICE

SIZE

A4

CAGE CODE

-

DRAWING NO

C-280004

RESTRICTED TO

-

CUSTOMER DRAWING

SCALE 5:1

SHEET 1 OF 1

REV B2